

Construction No. 508A

Uplift-Class 90

Fire Not Investigated

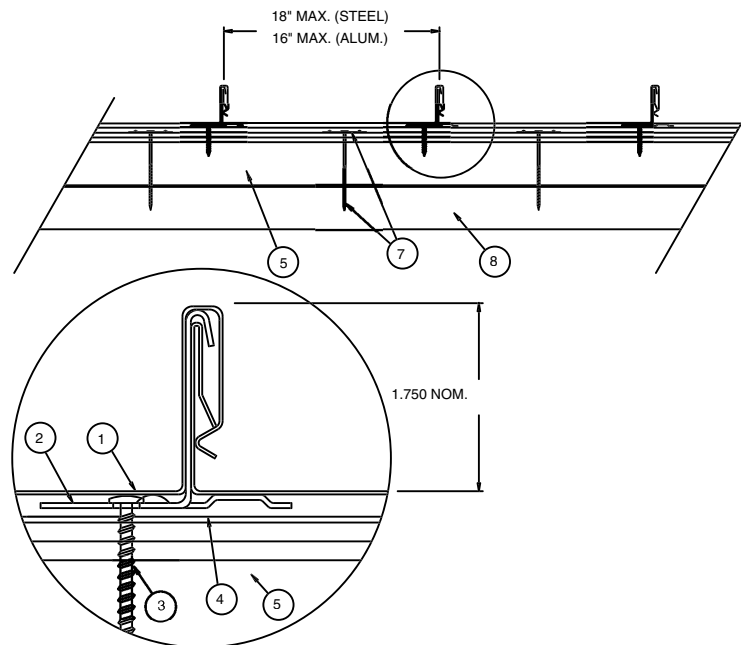

1. **Metal Roof Deck Panels*** - No. 24 MSG min thick coated steel panels, 18 in., 16 in., 12 in. or 10 in. wide or 0.032 in. min thick aluminum, 16 in., 12 in. or 10 in wide; 1-3/4 in. high at female side rib. Panels continuous over three or more clips with no end laps. A bead of sealant may be used at panel side joints.
Petersen Aluminum Corp. – “Snap-Clad”
2. **Roof Deck Fasteners* (Panel Clips)** – One piece assembly, 3-1/2 in. wide, 1-7/8 in. high. No. 18 MSG min thick coated steel. Clips spaced 36 in. OC max for steel panels and 18 in. OC max for aluminum panels. Fastened to nailable insulation (Item 5).
Petersen Aluminum Corp. – “Snap-Clad Clip”
3. **Fasteners (Screws)** – Fasteners used to attach panel clip (Item 2) to nailable insulation (Item 5) to be No. 10-12 by 1 in. long pancake head, No. 2 Phillips drive, A-point coated steel screws. Min two fasteners per clip.
4. **Underlayment** – Underlayment used over nailable insulation (Item 5) to be Type 30 organic felt. Sides overlapped min 2 in. End laps per manufacturer’s instructions. Felt nailed to nailable insulation with 1 in. long galvanized steel roofing nails, located in side laps and between side lap per manufacturer’s instructions. Nail spacing to be max 12 in. OC at the side lap and max 24 in. OC in interior rows.
5. **Nailable Insulation** – Consisting of 1 in. min. to 3-1/2 in. max thick Classified polyisocyanurate foamed plastic with a factory laminated 7/16 in. thick APA rated O.S.B. Density of foamed plastic to be 2 pcf.
6. **Supports (Purtins)** – (Not Shown) – Purlins used for liner panel (Item 8) support to be cold formed steel sections. As Alternatives, structural steel components (hot rolled beams, channels, open web joists, etc.) may be used. Min gauge and yield to depend on design considerations for uplift loading. Spacing to depend on design considerations for uplift loading with max spacing to be 6 ft. OC.
7. **Fasteners (Screws)** – Fasteners used to attach nailable insulation (Item 5) to liner panel (Item 8) to be No. 11-13, No. 3 Phillips drive, truss head, painted steel screws. Length to depend on overall thickness of deck and to penetrate steel deck ? in. min.
A 2 in. diameter formed pressure plate fabricated from No. 22 MSG coated steel to be used with each screw. Fasteners located in three rows along the 8 ft. length of the nailable insulation beginning 6 in. from the 8 ft. edges with a row down the center and spaced 21 in. OC beginning 6 in. from the 4 ft. edges. A total of 15 fasteners used for each 4 by 8 ft. board.
8. **Liner Panel (Steel Deck)** – No. 22 MSG min thick coated steel. Min depth 1-1/2 in., max pitch 6 in. fabricated to various profiles. Min yield strength 33,000 psi. Fastened to supports (Item 6) with fastener type and spacing per liner panel manufacturer’s instructions for uplift loading.
9. **Gypsum Board** – (Optional) – (Not Shown) – Max thick 5/8 in. supplied in 4 by 8 ft. sheets. Butt joints located over crests of metal roof deck panel (Item 1). Fastened to panel with same fasteners used for nailable insulation (Item 5).
Refer to General Information, Roof Deck Construction (Roofing Materials and Systems Directory) for items not evaluated.

*Bearing the UL Classification Marking